

THE REQUIREMENTS FOR ACQUIRING THE PRODUCT(S) DESCRIBED HEREIN SHALL CONSIST OF THIS SPECIFICATION SHEET AND THE ISSUE OF THE FOLLOWING SPECIFICATION LISTED IN THAT ISSUE OF THE DODISS SPECIFIED IN THE SOLICITATION: NONE

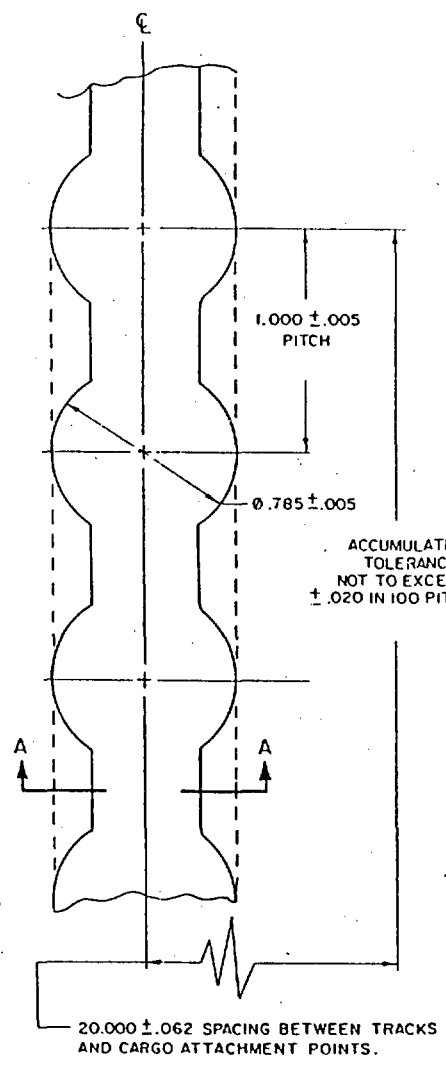

ACCUMULATED TOLERANCE NOT TO EXCEED ± .020 IN 100 PITCHES

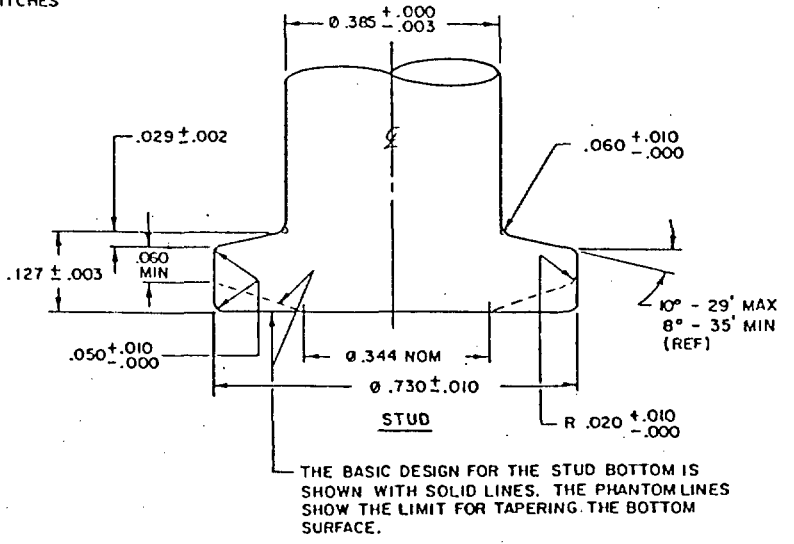
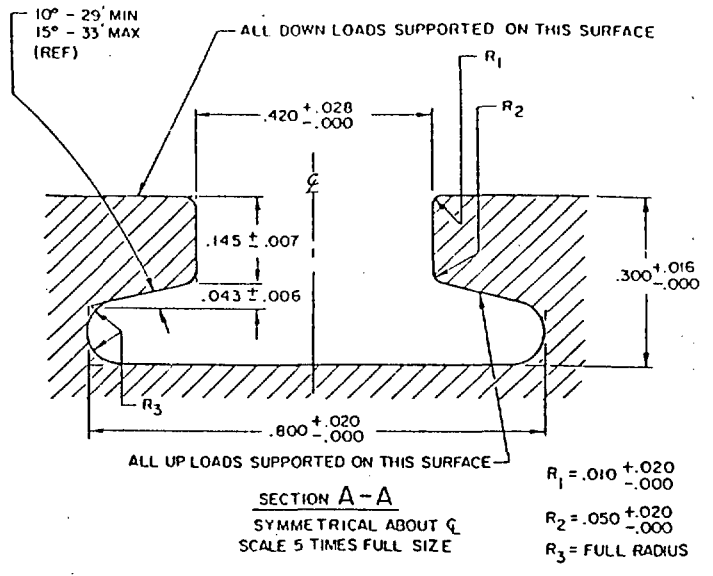

NOTES:

1. THIS SPECIFICATION SHEET DEPICTS THE CONFIGURATIONS AND DIMENSIONS OF TRACKS AND STUDS FOR SEAT ATTACHMENTS FOR SEATS AND OTHER EQUIPMENT IN CARGO/TRANSPORT AIRCRAFT.
2. CERTAIN PROVISIONS OF THIS SPECIFICATION SHEET ARE THE SUBJECT OF INTERNATIONAL STANDARDIZATION AGREEMENT. WHEN AMENDMENT, REVISION, OR CANCELLATION OF THIS SPECIFICATION SHEET IS PROPOSED THAT WILL MODIFY THE INTERNATIONAL AGREEMENT CONCERNED, THE PREPARING ACTIVITY WILL TAKE APPROPRIATE ACTION THROUGH INTERNATIONAL STANDARDIZATION CHANNELS, INCLUDING DEPARTMENTAL STANDARDIZATION OFFICES, TO CHANGE THE AGREEMENT OR MAKE OTHER APPROPRIATE ACCOMODATIONS.
3. DIMENSIONS ARE IN INCHES.

DESIGN STANDARD

PREPARING ACTIVITY: NAVY-AS CUSTODIANS: ARMY-AV NAVY-AS AIR FORCE-99 DLA-	MILITARY SPECIFICATION SHEET TITLE TRACK AND STUD FITTING FOR CARGO TRANSPORT AIRCRAFT, STANDARD DIMENSIONS FOR.	SPECIFICATION SHEET NUMBER REV B MS33601 31 JULY 1991 SUPERSEDING REV A MS33601 (ASG) 1 DEC 1965 AMSC- N/A FSC 1560
---------------------------------------------------------------------------------	---------------------------------------------------------------------------------------------------------------------	----------------------------------------------------------------------------------------------------------------------------------------

THIS SPECIFICATION IS APPROVED FOR USE BY ALL DEPARTMENTS AND AGENCIES OF THE DEPARTMENT OF DEFENSE.